

GHE

Dehumidifiers for radiant cooling systems with heat recovery

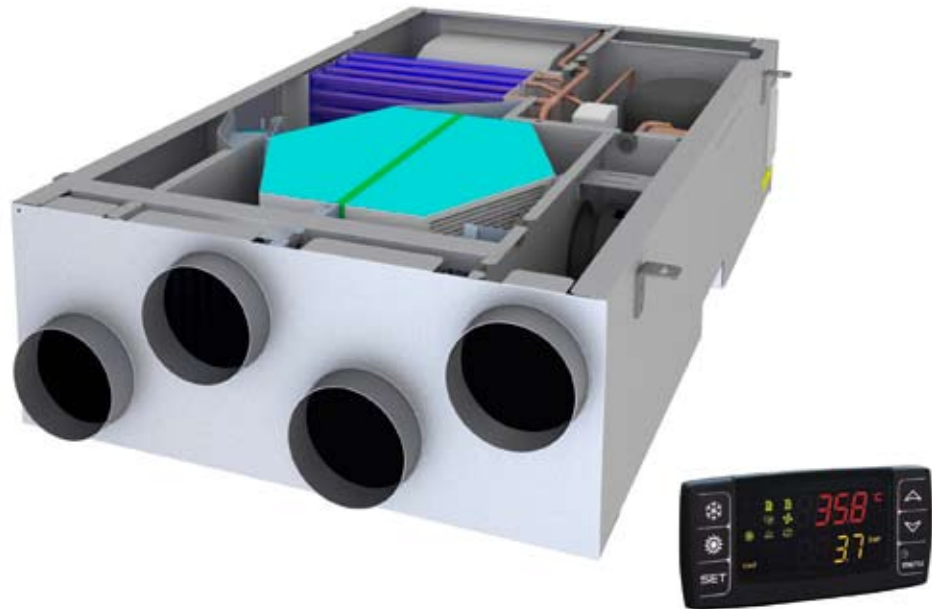

GHE

The dehumidifiers with heat recovery of high efficiency series GHE were designed to provide dehumidification and fresh air in a residential area with very high energy efficiency, combined with radiant cooling systems.

The units have been designed to grant the dehumidification either under conditions of thermally neutral air or in terms of air-cooled, managing small air flow thus avoiding annoying tiny air currents typical of traditional air conditioning systems.

The units consist of a direct expansion cooling system combined with a cross flow heat exchanger highly efficient, designed for heat recovery and air exchange environment in compliance with applicable regional and national laws.

VERSIONS

- FC** **FREE COOLING:** allows the air to avoid unnecessary switching on the cooling circuit, thus granting excellent environmental conditions with high energy savings. The Free Cooling option is perfect in the middle seasons, when heating or cooling systems are not in use.

ACCESSORIES

- HYGR** Remote mechanical hygostat + thermostat
- INSE** Serial interface card RS485.
- PCRL** Remote control panel.
- RGDD** Built in electronic temperature-humidity sensor.

Models GHE		26	51
Useful dehumidification capacity (from the net hygroscopic content of the external air) ⁽¹⁾	l/24h	30,1	61,8
Total cooling Power (latent + sensible) ⁽¹⁾	W	1380	2820
Recovered winter heating power ⁽²⁾	W	950	1850
Efficiency winter recovery ⁽²⁾	%	90%	90%
Efficiency summer recovery ⁽¹⁾	%	75%	72%
Power supply	V/Ph/Hz	230/1/50	230/1/50
Compressor absorbed power ⁽¹⁾	W	340	480
Supply fan absorbed power: minimum=nominal+maximum	W	10 ÷ 30 ÷ 86	30 ÷ 60 ÷ 130
Return fan absorbed power	W	11 ÷ 22 ÷ 43	22 ÷ 44 ÷ 68
Supply fan nominal useful prevalence	Pa	50 ÷ 140	50 ÷ 140
Return fan nominal useful prevalence	Pa	50 ÷ 140	50 ÷ 140
Min-max coil water flow	l/h	150 ÷ 250 ÷ 400	200 ÷ 350 ÷ 600
Min-max water pressure drop	kPa	15	35
Outdoor air flow	m³/h	80 ÷ 130	140 ÷ 250
Supply air flow	m³/h	130 ÷ 260	250 ÷ 500
Coolant type		R134a	R410A
Sound power level ⁽³⁾	dB(A)	47	52
Sound Pressure Level ⁽⁴⁾	dB(A)	39	44

Performance refer to the following conditions:

(1)Room Temp. 26°C; 65% RU; Ambient Temp. 35°C; 50% RU; Fresh Air System volume 130 m³/h (GHE26), 250 m³/h(GHE51); Water IN 15°C, Water Flow 250 l/h(GHE26), 350l/h(GHE51).

(2)Ambient Temp. -5°C; 80% RU; Room Temp. 20°C; Fresh Air system at maximum.

(3)Sound Power level according to ISO 9614.

(4)Sound Pressure level measured at 1 mt from the unit in free field conditions according with ISO 9614, at the normal working conditions.

TYPICAL INSTALLATION

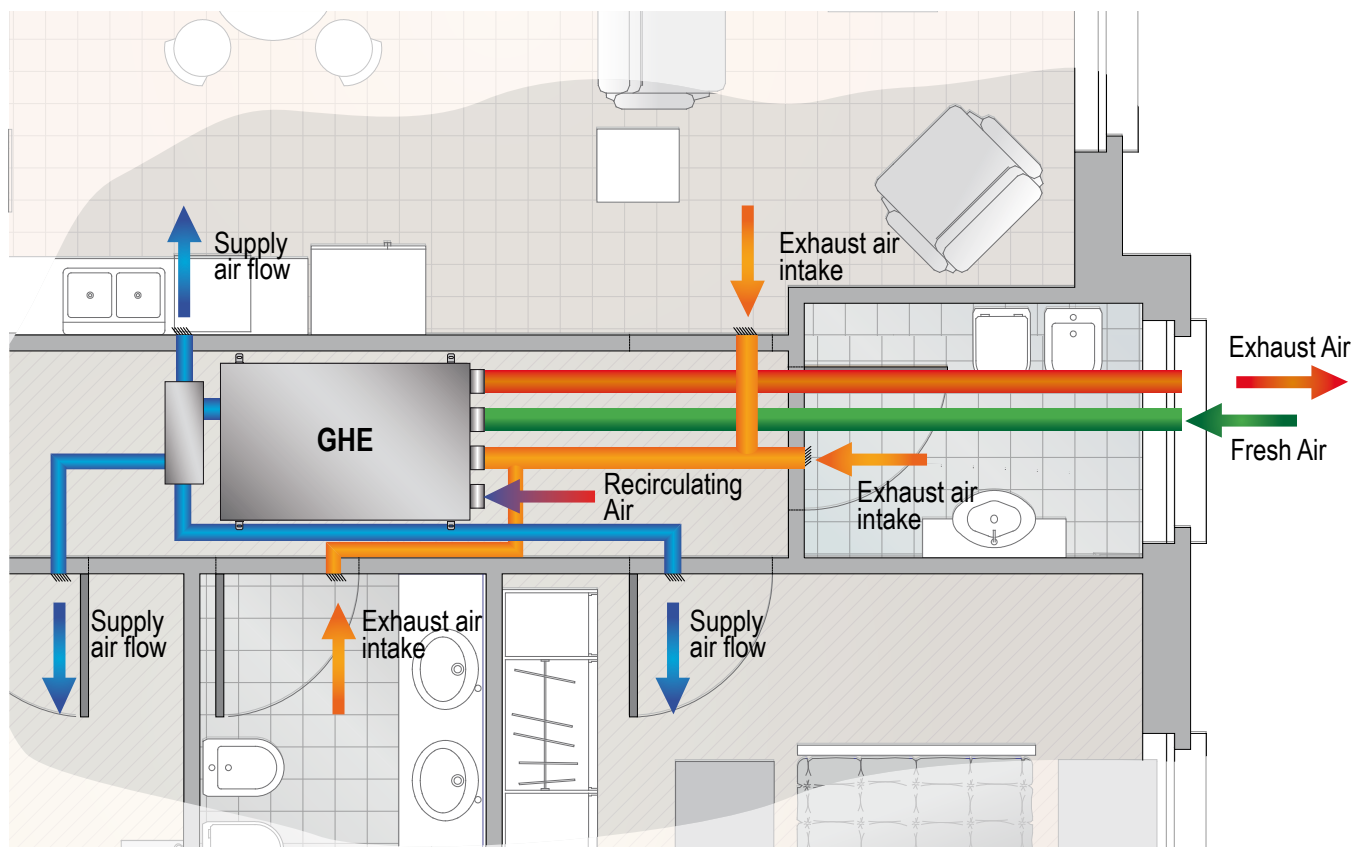

FRAME

All units are made from hot-galvanised thick sheet metal, to ensure the best resistance against the corrosions. The frame is self-supporting with removable panels. The drip tray is present standard in all units.

REFRIGERANT CIRCUIT

The refrigerant circuit is made by using international primary brands components and according to ISO 97/23 concerning welding procedures. The refrigerant gas used in these units is R134a for the model 26 and R407C for the models 51.

COMPRESSOR

The compressor is alternative for model 26 and rotative type for model 51, equipped and thermal overload protection by a klixon embedded in the motor winding. It's mounted on rubber vibration dampers to reduce the noise.

HEAT EXCHANGERS

The heat exchangers are made of copper pipes and aluminium fins. The diameter of the copper pipes is 3/8" and the thickness of the aluminium fins is 0,1 mm. The tubes are mechanically expanded into the aluminium fins to improve the heat exchange factor. The geometry of these condensers guarantees a low air side pressure drop and then the use of low rotation (and low noise emission) fans. All the units have a stainless steel drip tray. Besides this, each evaporator is supplied of a temperature

probe used as automatic antifreeze probe.

FANS

The supply fan is centrifugal type, double inlet with forwards blades, with EC Fan motor directly connected. The exhaust fan is plug fan type with backwards blades, with EC fan motor directly connected.

AIR FILTER

It's supplied standard with the unit. It's made of filtering material in synthetic fibre without electrostatic charge. It can be removed for differential disposal, class G5, according to EN 779:2002.

HEAT RECOVERY

Hexagonal cross-flow heat recovery with PVC plates, high efficiency (90%).

ADJUSTMENT MICRO SWITCHES

Used during calibration of fans air flow depending on the ducts pressure drop .

MICROPROCESSOR

All GHE units are supplied with an advanced software for the complete control of the hydronic and air distribution side.

The software can manage:

- The management of the operation according to a probe of temperature and humidity.
- Activation of the dehumidification based on the pre set humidity conditions.
- Activation of of winter or summer sensible load integration, according to the summer or winter set point

- Management of supply air temperature through discharge limit probe sensor (standard).
- Modulating valve for the proper management of the water battery power
- Ventilation Management directly from built-in timer in the microprocessor (optional).
- Management damper
- Machine Allarm display
- Supervisor and BMS connection through serial card RS485 (Optional) a/o XWEB Module (Optional).
- Clogged filters management (optional).
- Antifreeze management.
- Summer/Winter commutation.

VERSIONS

FREE COOLING (FC) (only for mod.26)

In these versions, the electronic control mounted on the machine, check the thermo-hygrometric conditions (indoor –outdoor), allows the air to avoid unnecessary switching on of the refrigerating circuit, thus ensuring excellent environmental conditions with high energy savings. The Free Cooling option is perfect in spring and autumn, when heating or cooling is not yet activated, or at night when the summer heat humidity conditions outside are often sufficient to ensure proper ventilation of rooms without the use of the refrigerant system.

REFRIGERANT CIRCUIT FUNCTIONING PRINCIPLES

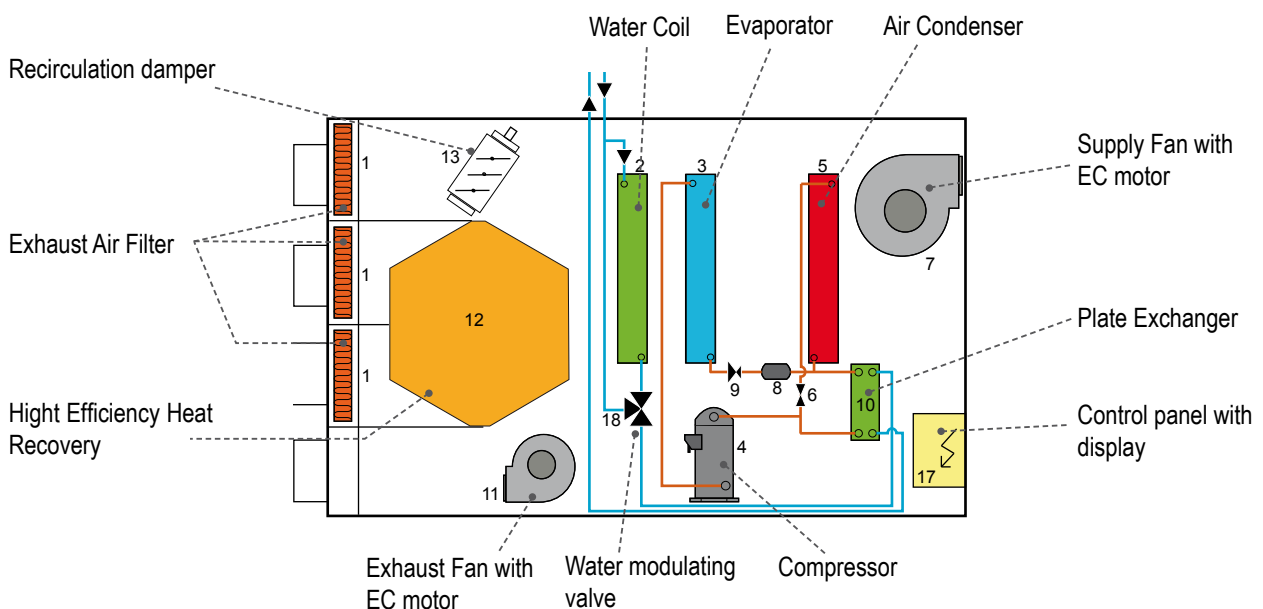

The functioning of the dehumidifier model GHE is as follows: the fan takes the air humid from the ambient through the fan (7) and it's made go through the filter (1) and the cross-flow heat (12) pre-cooling water coil (2) where it's cooled and brought to a condition closed to saturation. Now it passes through the evaporating coil (3) where it's further cooled and dehumidified. At this time the functionality mode may be. The air passes now through the condensing coil (5) where it's post heated (with a constant

humidity) and in cooling, when the solenoid valve (6) open where it's reported to the required conditions.

Dehumidification with neutral air:

The cooling system works partially in the water through the plate exchanger (10) and partially in the air with the air condenser (5) which will then make a post-heating at constant humidity blowing air in in the room in thermally neutral conditions.

Dehumidification with cooling:

The cooling circuit, in this case, performing works 100% of the condensation in the water through the plate exchanger (10), the air condenser (5) is intercepted by the valve (6) and the air supplied in the room is the same as leaving the evaporator coil (3), cold and dried.

AERAUIC CIRCUIT FUNCTIONING PRINCIPLES:

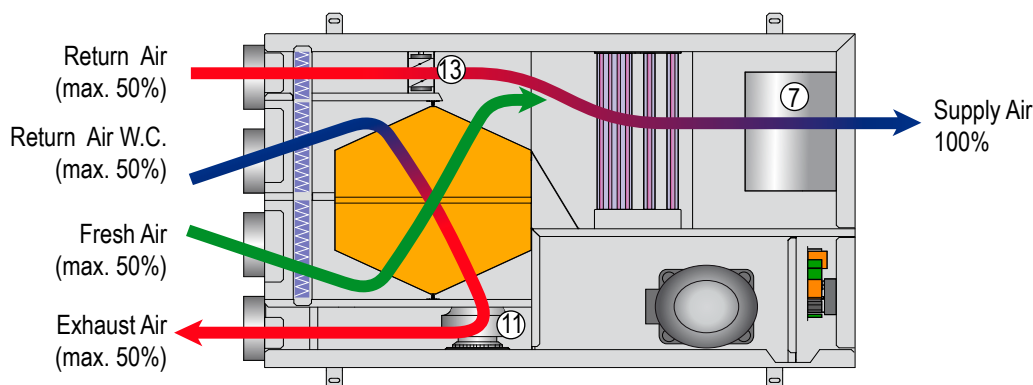

GHE 26 units can operate with a flow rate of outdoor air from 80 to 130 m³/h (140 to 260 m³/h for the model GHE 51), to ensure sufficient supply air changes in the room having a variable volume by 260 m³ (0.5 vol/h) to 460 m³ (0.3 vol/h), in compliance with regional and national regulations. The air flow

rate of discharge can vary from 80 to 130 m³/h (140-260 m³/h for the model 51) in the winter mode, and is fixed to 260 m³/h (500 m³/h for the model 51) in summer mode. The cross-flow heat exchanger of high efficiency is designed to ensure a recovery rating of 90% in terms of air temperature -5°C

and air temperature 20°C. The stale air is expelled from the environment by the fan (11), while the outside air is sucked through the fan (7). The proper balance of air flows is ensured by the damper (13) that handles both the balance of flows of air that the air flow recirculation summer.

SUMMER OPERATION (COMPRESSON ON)

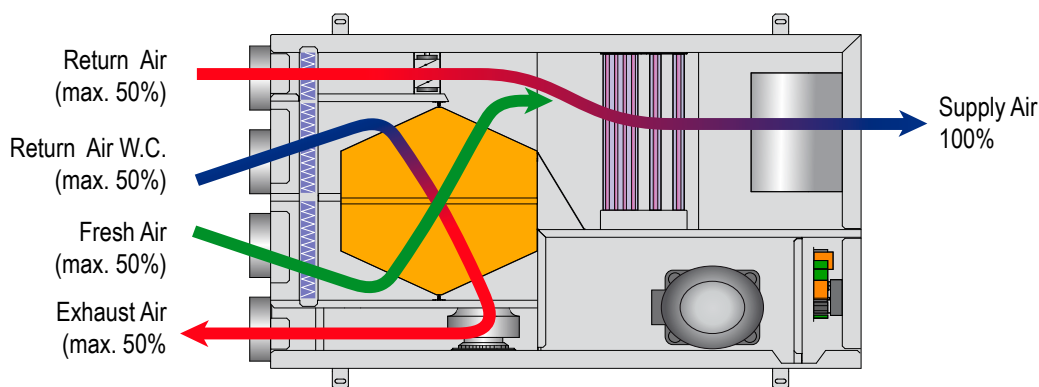

When this selected mode the unit renews the ambient air with the outside through the heat exchanger for high efficiency, air flow is increased so as to allow operation of refrigerant circuit; for this purpose the recirculation damper will be open, the supply fan is operated at maximum capacity and the unit works with external air and partial recirculation.

THE POSSIBLE FUNCTIONS IN THIS CONFIGURATION ARE

- Renewal + Air Dryers neutral: The condensing unit partially in air and partially in the water through the condenser plate, obtaining dry air and thermally neutral.

- Renewal + Dehumidification with cooling: The unit operates with 100% of the condensation water, obtaining dry and cooled air.

WINTER OPERATION AND MIDDLE SEASON (COMPRESSOR OFF)

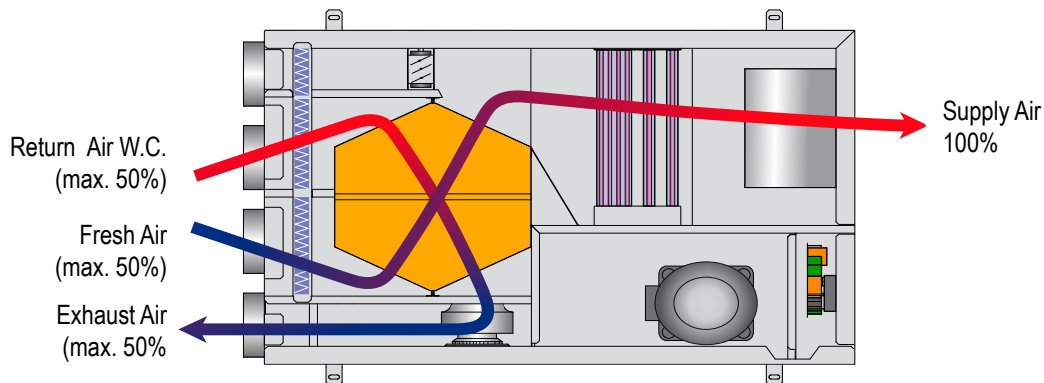

When this selected mode, the unit renews the ambient air with the outside through the heat exchanger of high efficiency. The air flow is reduced to the value required by the standard (0.3 ÷ 0.5 vol/h), the recirculation damper is closed and the unit operates with 100% fresh air.

THE POSSIBLE FUNCTIONS IN THIS CONFIGURATION ARE

- Renewal with heated air: The compressor is switched off, the battery can be supplied with hot water from radiant system. (even due to the high efficiency of the heat

exchanger, is able to obtain a supply air temperature 17°C, without using hot water and ambient air temperature of -5°C), and behaves like a normal air handling with recovery.

FRESH AIR WITH FREE COOLING

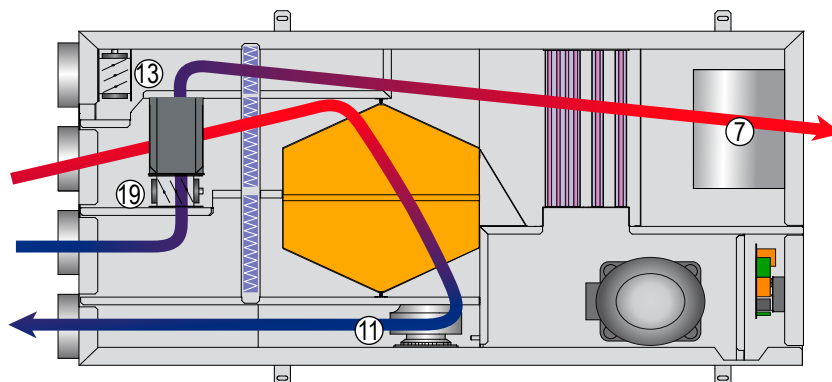

The compressor is off, the water coil is not powered (3-way valve closed), the recirculation damper (13) is closed, the damper by-pass of the recuperator (19) is open.

The stale air is fully exhausted into the environment by the fan (11) Meanwhile outside air is sucked by the fan (7) bypasses the heat recovery and comes at the room

with temperature and relative humidity without modification. During the free cooling mode the flow rate of outside air is equal to the flow rate of the supply air in the environment.

Versions GHE	Code	26	51
Microprocessor control		●	●
Flow meter		●	●
Modulating 3-way valve		●	●
Supply & Return EC fans		●	●
G4 air filter		●	●
Adjustable Trimmers		●	●
High Efficiency Heat Recovery		●	●
Remote control Panel	PCRL	○	○
Thermo- Mechanical remote Hygrostat	HYGR	○	○
Umidity and Temperature electronic probe sensor	RGDD	○	○
Serial interface card RS485	INSE	○	○
High efficiency electronic air filter	FC	○	–

● Standard, ○ Optional, – Not available.

SUMMER AIR TREATMENT

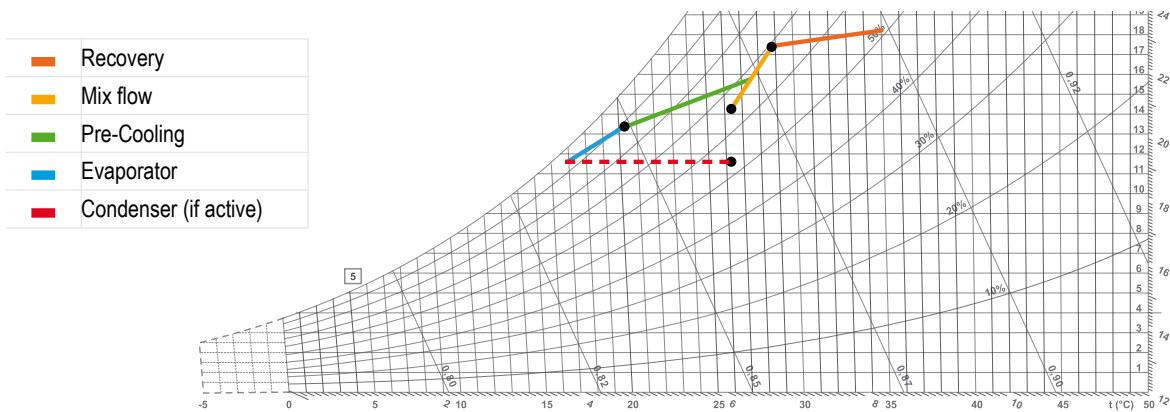

GHE

STANDARD VERSION

FREE COOLING VERSION (only mod. 26)

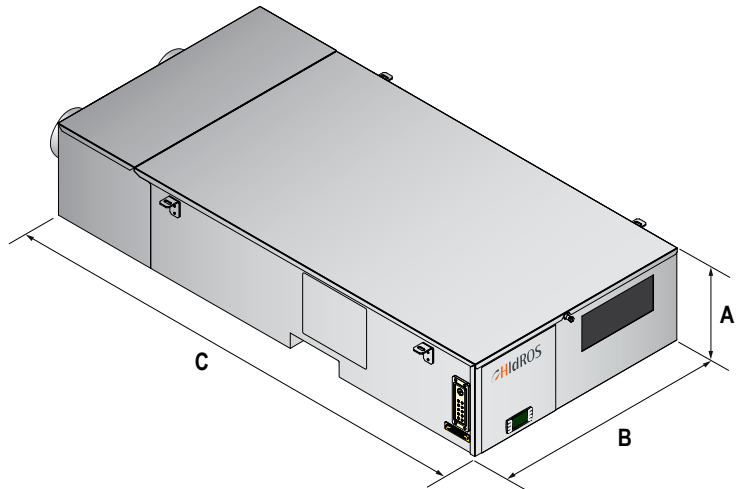
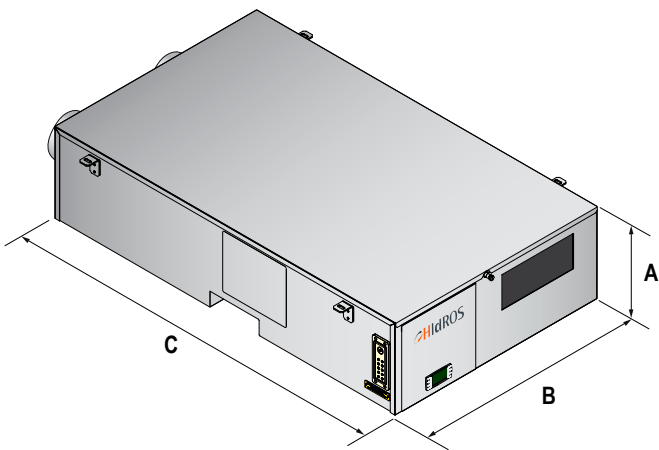

Mod.	A (mm)	B (mm)	C (mm)	Kg
26	260	732	1105	60
51	400	835	1370	80
26/FC	260	732	1355	95